

Product Manual

1018 - PhidgetInterfaceKit 8/8/8

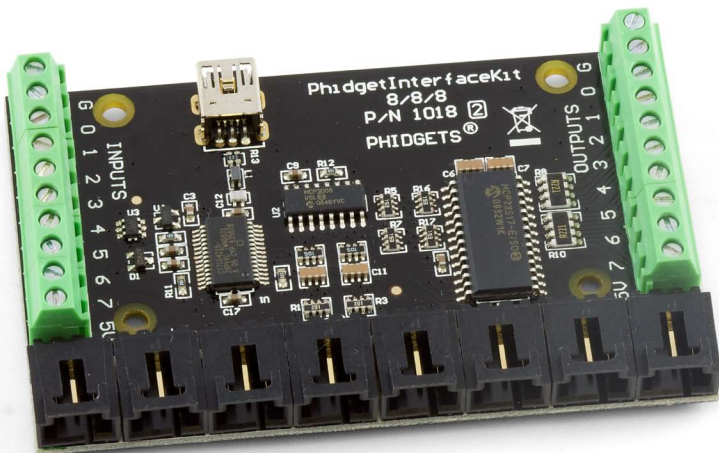

Phidgets 1018 - Product Manual
For Board Revision 2
© Phidgets Inc. 2010

Contents

5 Product Features

- 5 Analog inputs
- 5 Digital Inputs
- 5 Digital Outputs
- 5 Programming Environment
- 5 Connection

6 Getting Started

- 6 Checking the Contents
- 6 Connecting all the pieces
- 6 Testing Using Windows 2000/XP/Vista
 - 6 Downloading the Phidgets drivers
 - 6 Running Phidgets Sample Program
- 8 Testing Using Mac OS X
- 8 If you are using Linux
- 8 If you are using Windows Mobile/CE 5.0 or 6.0

9 Programming a Phidget

- 9 Architecture
- 9 Libraries
- 9 Programming Hints
- 9 Networking Phidgets
- 10 Documentation
 - 10 Programming Manual
 - 10 Getting Started Guides
 - 10 API Guides
- 10 Code Samples
- 10 API for the InterfaceKit 8/8/8
 - 10 Functions
 - 11 Events

12 Technical Section

- 12 Analog Inputs
 - 12 Using the Analog Inputs with Sensors provided by Phidgets

12	Using the Analog Inputs with your own sensors
12	Mechanical
12	Electrical
12	Ratiometric Configuration
13	Non-Ratiometric Configuration
13	Factors that can affect Accuracy
13	Changing the Data Rate
13	Connecting non-Phidget devices to the Analog Inputs
14	Interfacing to an arbitrary sensor
14	Non Phidgets Sensors
15	Digital Inputs
15	Digital Input Hardware Filter
15	Digital Input Hysteresis
15	Digital Input Sampling Characteristics
15	5Volt Terminal Block
15	Functional Block Diagram
15	Using the Digital Inputs
18	Digital Outputs
18	Functional Block Diagram
18	Ground Protection
18	5Volt Terminal Block
18	Using the Digital Outputs
20	Device Specifications

21 Product History

21 Support

Product Features

The PhidgetInterfaceKit 8/8/8 allows you to connect devices to any of 8 analog inputs, 8 digital inputs and 8 digital outputs. It provides a generic, convenient way to interface your PC with various devices.

Analog inputs

Analog Inputs are used to measure continuous quantities, such as temperature, humidity, position, pressure, etc. Phidgets offers a wide variety of sensors that can be plugged directly into the board using the cable included with the sensor. Here is a list of sensors currently available:

IR Distance Sensor	IR Reflective Sensor	Vibration Sensor	Light Sensor
Force Sensor	Humidity Sensor	Temperature Sensor	Magnetic Sensor
Rotation Sensor	Voltage Divider	Touch Sensor	Motion Sensor
Mini Joy-Stick	Pressure Sensor	Voltage Sensor	Current Sensor
Slide Sensor	Sound Sensor		

Each analog input can be adjusted to sample at a data rate ranging from 1 sample to up to 1000 samples per second. Samples are transmitted to your PC every 8ms. This feature is very useful for setting up the resolution of your data logging. Note that data rate is limited to 16ms when opening over the Phidget Webservice.

Digital Inputs

Digital Inputs can be used to convey the state of push buttons, limit switches, relays, logic levels, etc...

We provide 8 digital input terminals, 1 Ground, and 1 5V.

Digital Outputs

Digital Outputs can be used to drive LEDs, solid state relays (have a look at our SSR board), transistors; in fact, anything that will accept a CMOS signal.

Digital outputs can be used to control devices that accept a +5V control signal.

We provide 8 digital output terminals, 1 Ground, and 1 5V.

With transistors and some electronics experience, other devices can be controlled, such as buzzers, lights, larger LEDs, relays.

Programming Environment

Operating Systems: Windows 2000/XP/Vista/7, Windows CE, Linux, and Mac OS X

Programming Languages (APIs): VB6, VB.NET, C#.NET, C++, Flash 9, Flex, Java, LabVIEW, Python, Max/MSP, and Cocoa.

Examples: Many example applications for all the operating systems and development environments above are available for download at www.phidgets.com >> Programming.

Connection

The board connects directly to a computer's USB port.

Getting Started

Checking the Contents

You should have received:

- A PhidgetInterfaceKit 8/8/8 board
- A Mini-USB Cable

In order to test your new Phidget you will also need:

- A piece of wire to test the digital inputs
- An LED to test the digital outputs
- An Analog Sensor to test the analog inputs.

Connecting all the pieces

1. Connect the Analog Sensor to the analog input port 6 using a Phidgets sensor cable. The analog ports are numbered from 0 to 7 starting from the left.
2. Connect the InterfaceKit board to the PC using the Mini-USB cable.
3. Connect one end of the wire to digital input port 0 and the other end to the ground connection.
4. Connect the LED by inserting the long LED wire into the digital output 0 and the shorter wire into Ground.

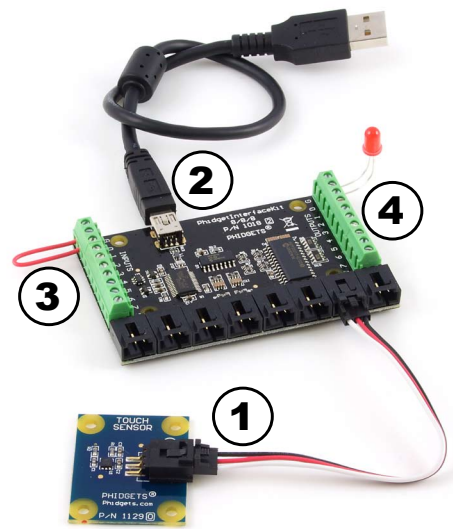

Testing Using Windows 2000/XP/Vista/7

Downloading the Phidgets drivers

Make sure that you have the current version of the Phidget library installed on your PC. If you don't, do the following:

Go to www.phidgets.com >> Drivers

Download and run Phidget21 Installer (32-bit, or 64-bit, depending on your PC)

You should see the  icon on the right hand corner of the Task Bar.

Running Phidgets Sample Program

Double clicking on the  icon loads the Phidget Control Panel; we will use this program to make sure that your new Phidget works properly.

The source code for the InterfaceKit-Full sample program can be found under C# by clicking on www.phidgets.com >> Programming.

Double Click on the  icon to activate the Phidget Control Panel and make sure that the **Phidget InterfaceKit 8/8/8** is properly attached to your PC.

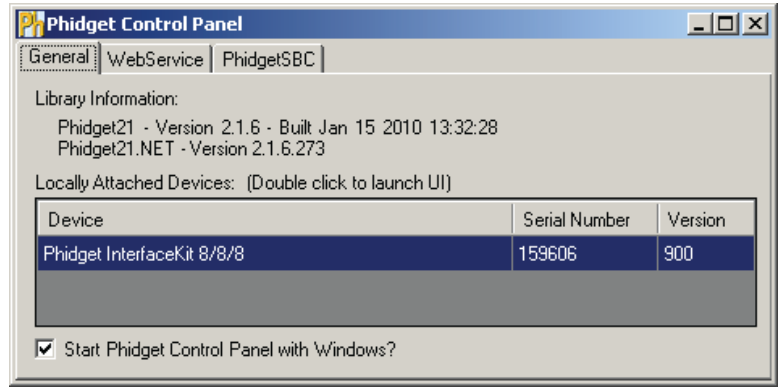

1. Double Click on **PhidgetInterfaceKit 8/8/8** in the Phidget Control Panel to bring up InterfaceKit-full and check that the box labelled Attached contains the word True.
2. Test the digital output by clicking on the white box to turn on the LED. Clicking again will turn the LED off. The bottom row shows the status of the request, while the top row displays the status of the digital output as reported by the device.

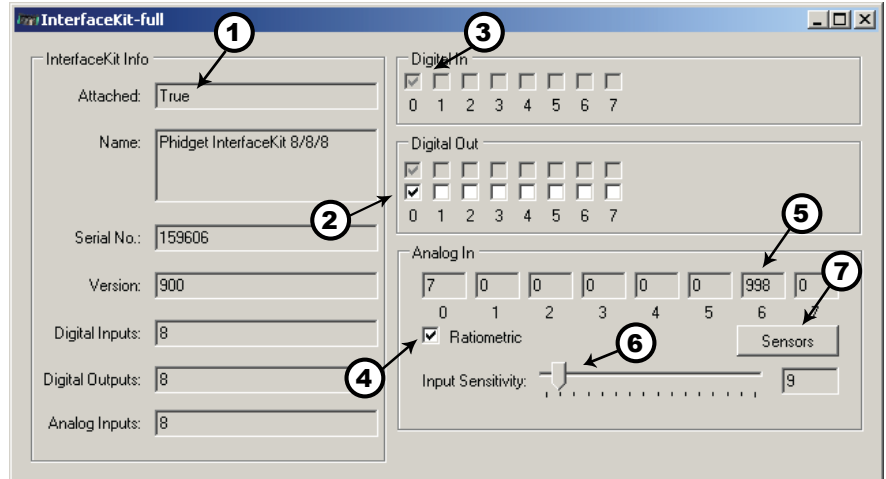

3. Test the digital input by disconnecting the wire end connected to the digital input connector. The tick mark in the box will go away.
4. Click on the Ratiometric Box if your sensor is ratiometric. Check the sensor product manual if you are not sure.
5. Test the Analog Input by activating your sensor and check your results in Analog In number 6.
6. You can adjust the input sensitivity by moving the slider pointer. This is the amount that an input must change to trigger an event that will modify the value in the Analog In box.
7. Click on Sensors to launch the Advanced Sensor Form.

1. In the drop down menu, select the Sensor you have attached to the analog input port 0 of the 1018. In our case we select the 1129 - Touch Sensor.
2. The state of the Touch Sensor is shown here.

Note: If you have connected a sensor that uses a formula, the calculated value and the formula are displayed under the drop down menu.

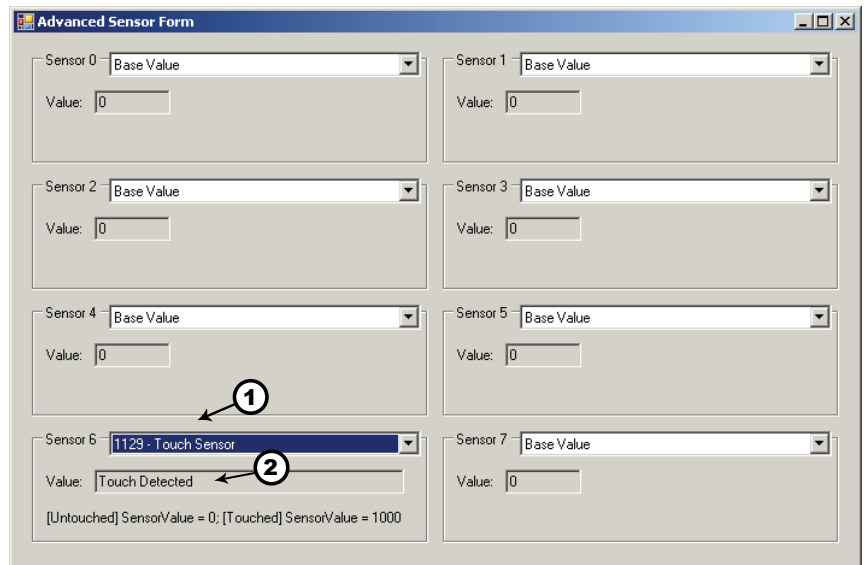

Testing Using Mac OS X

- Click on System Preferences >> Phidgets (under Other) to activate the Preference Pane
- Make sure that the Phidget InterfaceKit 8/8/8 is properly attached.
- Double Click on Phidget InterfaceKit 8/8/8 in the Phidget Preference Pane to bring up the InterfaceKit-Full example. This example will function in a similar way as the Windows version, but note that it does not include an Advanced Sensor Display.

If you are using Linux

There are no sample programs written for Linux.

Go to www.phidgets.com >> Drivers

Download Linux Source

- Have a look at the readme file
- Build Phidget21

There is no Control Panel written for Linux, but there are C/C++ and Java code samples available for all Phidgets which will compile and run on Linux without modification.

Notes:

Many Linux systems are now built with unsupported third party drivers. It may be necessary to uninstall these drivers for our libraries to work properly.

Phidget21 for Linux is a user-space library. Applications typically have to be run as root, or udev/hotplug must be configured to give permissions when the Phidget is plugged in.

If you are using Windows Mobile/CE 5.0 or 6.0

Go to www.phidgets.com >> Drivers

Download x86, ARMV4I or MIPSII, depending on the platform you are using. Mini-itx and ICOP systems will be x86, and most mobile devices, including XScale based systems will run the ARMV4I.

The CE libraries are distributed in .CAB format. Windows Mobile/CE is able to directly install .CAB files.

The most popular languages are C/C++, .NET Compact Framework (VB.NET and C#). A desktop version of Visual Studio can usually be configured to target your Windows Mobile Platform, whether you are compiling to machine code or the .NET Compact Framework.

Programming a Phidget

Phidgets' philosophy is that you do not have to be an electrical engineer in order to do projects that use devices like sensors, motors, motor controllers, and interface boards. All you need to know is how to program. We have developed a complete set of Application Programming Interfaces (API) that are supported for Windows, Mac OS X, and Linux. When it comes to languages, we support VB6, VB.NET, C#.NET, C, C++, Flash 9, Flex, Java, LabVIEW, Python, Max/MSP, and Cocoa.

Architecture

We have designed our libraries to give you the maximum amount of freedom. We do not impose our own programming model on you.

To achieve this goal we have implemented the libraries as a series of layers with the C API at the core surrounded by other language wrappers.

Libraries

The lowest level library is the C API. The C API can be programmed against on Windows, CE, OS X and Linux. With the C API, C/C++, you can write cross-platform code. For systems with minimal resources (small computers), the C API may be the only choice.

The Java API is built into the C API Library. Java, by default is cross-platform - but your particular platform may not support it (CE).

The .NET API also relies on the C API. Our default .NET API is for .NET 2.0 Framework, but we also have .NET libraries for .NET 1.1 and .NET Compact Framework (CE).

The COM API relies on the C API. The COM API is programmed against when coding in VB6, VBScript, Excel (VBA), Delphi and Labview.

The ActionScript 3.0 Library relies on a communication link with a PhidgetWebService (see below). ActionScript 3.0 is used in Flex and Flash 9.

Programming Hints

- Every Phidget has a unique serial number - this allows you to sort out which device is which at runtime. Unlike USB devices which model themselves as a COM port, you don't have to worry about where in the USB bus you plug your Phidget in. If you have more than one Phidget, even of the same type, their serial numbers enable you to sort them out at runtime.
- Each Phidget you have plugged in is controlled from your application using an object/handle specific to that phidget. This link between the Phidget and the software object is created when you call the .OPEN group of commands. This association will stay, even if the Phidget is disconnected/reattached, until .CLOSE is called.
- For full performance, the Phidget APIs are designed to be used in an event driven architecture. Applications that require receiving all the data streaming from the device will have to use event handlers, instead of polling.

Networking Phidgets

The PhidgetWebService is an application written by Phidgets Inc. which acts as a network proxy on a computer. The PhidgetWebService will allow other computers on the network to communicate with the Phidgets connected to that computer. ALL of our APIs have the capability to communicate with Phidgets on another computer that has the PhidgetWebService running.

The PhidgetWebService also makes it possible to communicate with other applications that you wrote and that are connected to the PhidgetWebService, through the PhidgetDictionary object.

Documentation

Programming Manual

The Phidget Programming Manual documents the Phidgets software programming model in a language and device unspecific way, providing a general overview of the Phidgets API as a whole. You can find the manual at www.phidgets.com >> Programming.

Getting Started Guides

We have written Getting Started Guides for most of the languages that we support. If the manual exists for the language you want to use, this is the first manual you want to read. The Guides can be found at www.phidgets.com >> Programming, and are listed under the appropriate language.

API Guides

We maintain API references for COM (Windows), C (Windows/Mac OSX/Linux), Action Script, .Net and Java. These references document the API calls that are common to all Phidgets. These API References can be found under www.phidgets.com >> Programming and are listed under the appropriate language. To look at the API calls for a specific Phidget, check its Product Manual.

Code Samples

We have written sample programs to illustrate how the APIs are used.

Due to the large number of languages and devices we support, we cannot provide examples in every language for every Phidget. Some of the examples are very minimal, and other examples will have a full-featured GUI allowing all the functionality of the device to be explored. Most developers start by modifying existing examples until they have an understanding of the architecture.

Go to www.phidgets.com >> Programming to see if there are code samples written for your device. Find the language you want to use and click on the magnifying glass besides "Code Sample". You will get a list of all the devices for which we wrote code samples in that language.

API for the InterfaceKit 8/8/8

We document API Calls specific to this product in this section. Functions common to all Phidgets and functions not applicable to this device are not covered here. This section is deliberately generic. For calling conventions under a specific language, refer to the associated API manual. For exact values, refer to the device specifications.

Functions

int InputCount() [get] : Constant = 8

Returns the number of digital inputs supported by this PhidgetInterfaceKit.

bool InputState(int InputIndex) [get]

Returns the state of a particular digital input. Digital inputs read True where they are activated and false when they are in their default state.

int OutputCount() [get] : Constant = 8

Returns the number of digital outputs supported by this PhidgetInterfaceKit.

bool OutputState (int OutputIndex) [get,set]

Sets/returns the state of a digital output. Setting this to true will activate the output, False is the default state. Reading the OutputState immediately after setting it will not return the value set - it will return the last state reported by the Phidget.

int SensorCount() [get] : Constant = 8

Returns the number of sensors (Analog Inputs) supported by this PhidgetInterfaceKit. Note that there is no way of determining if a sensor is attached, and what sensor is attached.

int SensorValue(int SensorIndex) [get]

Returns the sensed value of a particular Analog Input. SensorValue varies between 0-1000, corresponding to the 0-5V input range of the Analog Input.

If you are using an Analog Sensor from Phidgets Inc., it's manual will specify the formula used to convert SensorValue into the measured property.

int SensorRawValue (int SensorIndex) [get]

Returns the full resolution of the Analog Input. This is a more accurate version of SensorValue. The valid range is 0-4095. Note however that the analog outputs on the Interface Kit 8/8/8 are only 10-bit values and this value represents an oversampling to 12-bit.

double SensorChangeTrigger (int SensorIndex) [get,set]

Returns the change trigger for an analog input. This is the amount that an inputs must change between successive SensorChangeEvents. This is based on the 0-1000 range provided by getSensorValue. This value is by default set to 10 for most Interface Kits with analog inputs. SensorChangeTrigger is sometimes referred to as sensitivity.

int DataRate (int SensorIndex) [get,set]

Gets/sets the data rate for an analog input. This corresponds to the fastest rate at which SensorChange events will be fired. The data rate is superseded by SensorChangeTrigger, which can be set to 0 if a constant data rate is required. Data Rate is in milliseconds and corresponds to the amount of time between events. Data Rate is bounded by DataRateMax and DataRateMin. The analog inputs cannot all be set to the fastest data rate at the same time - if this is attempted, an exception will be thrown when the data bandwidth has been exceeded. For data rates less than the maximum, data is still sampled at the maximum speed, and averaged between events for the user. Supported data rates are: 1, 2, 4, 8, and every multiple of 8 until DataRateMin. Setting an unsupported data rate (ie. 3, 9, 17) will result in a thrown exception. Note that data rate is limited to 16ms when opening over the Phidget Webservice.

int DataRateMax (int SensorIndex) [get]

The maximum data rate that can be set for an analog input, in milliseconds.

int DataRateMin (int SensorIndex) [get]

The minimum data rate that can be set for an analog input, in milliseconds. This is usually 1000.

bool Ratiometric() [get,set]

Sets/returns the state of Ratiometric. Ratiometric = true configures the Analog Inputs to measure w.r.t VCC (nominal 5V). Ratiometric = false configures the Analog Inputs to measure w.r.t an internal precision 5V reference. Ratiometric is not updated from the Phidget. It is recommended to explicitly set Ratiometric when the Interfacekit is opened. After changing the ratiometric state, wait until the ratiometric property matches what was set before reading analog data.

Events

OnInputChange(int InputIndex, bool State) [event]

An event that is issued when the state of a digital input changes.

OnOutputChange(int OutputIndex, bool State), [event]

An event that is issued when the state of a digital output changes.

OnSensorChange(int SensorIndex, int SensorValue), [event]

An event that is issued when the returned value from a sensor (Analog Input) varies by more than the SensorChangeTrigger property.

Technical Section

Analog Inputs

Using the Analog Inputs with Sensors provided by Phidgets

Analog Inputs are used to interface many different types of sensors. Each Analog Input provides power (Nominal +5VDC), ground, and an analog voltage return wire driven by the sensor to some voltage. The PhidgetInterfaceKit continuously measures this return voltage and reports it to the application.

Analog Inputs are used to measure continuous quantities, such as temperature, humidity, position, pressure, etc. Phidgets offers a wide variety of sensors that can be plugged directly into the board using the cable included with the sensor.

Using the Analog Inputs with your own sensors

For users who wish to interface their own sensors, we describe the Analog Inputs here.

Mechanical

Each Analog Input uses a 3-pin, 0.100 inch pitch locking connector. Pictured here is a plug with the connections labeled. The connectors are commonly available - refer to the Table below for manufacturer part numbers.

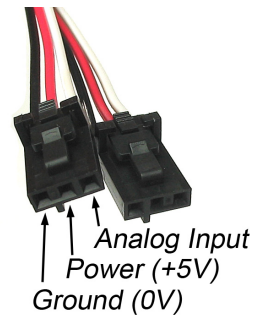

Cable Connectors		
Manufacturer	Part Number	Description
Molex	50-57-9403	3 Position Cable Connector
Molex	16-02-0102	Wire Crimp Insert for Cable Connector
Molex	70543-0002	3 Position Vertical PCB Connector
Molex	70553-0002	3 Position Right-Angle PCB Connector (Gold)
Molex	70553-0037	3 Position Right-Angle PCB Connector (Tin)
Molex	15-91-2035	3 Position Right-Angle PCB Connector - Surface Mount

Note: Most of the above components can be bought at www.digikey.com

Electrical

The maximum total current consumed by all Analog Inputs should be limited to 400mA.

The analog measurement is represented in the software through the SensorValue as a value between 0 and 1000. A sensor value of 1 unit represents a voltage of approximately 5 millivolts. The RawSensorValue property brings out a 12-bit value (0-4095) for users who require maximum accuracy. Please note that the sampling is actually done with an oversampled 10-bit ADC, but reported as a 12-bit value to allow future expansion.

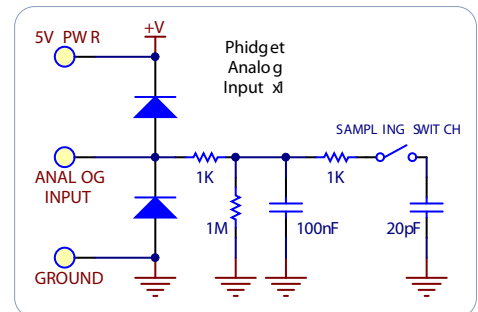

Ratiometric Configuration

The group of Analog Inputs can be collectively set to Ratiometric mode from software using the Ratiometric property. If you are using a sensor whose output changes linearly with variations in the sensor's supply voltage level, it is said to be ratiometric. Most of the sensors sold by Phidgets are ratiometric (this is specified on the web product page and in the sensor's product manual).

Setting Ratiometric causes the reference to the internal Analog to Digital Converter to be set to the power supply voltage level. When Ratiometric is enabled, the maximum voltage returned on the Analog Input should be the +5V nominal power provided by the PhidgetInterfaceKit.

Non-Ratiometric Configuration

If Ratiometric is false, the ADC reference is set to a 5.0V 0.5% stable voltage reference. The maximum voltage returned on the Analog Input should be maximum 5.0V. Note that the Analog Input power supply voltage is not affected by the setting of the Ratiometric property.

Factors that can affect Accuracy

High Output Impedance - Sensors that have a high output impedance will be distorted by the 900K input impedance of the Analog Input. If your output impedance is high, it is possible to correct for this distortion to some extent in your software application.

Power Consumption - Sensor cables have some resistance, and the power consumption of the sensor will cause the sensor to have a slightly different ground from the Analog Input on the PhidgetInterfaceKit. The more power consumed by the sensor, and the longer the sensor cable, the more pronounced this effect will be.

Intrinsic Error In Sensors - For many sensors, the error is quite predictable over the life of the sensor, and it can be measured and calibrated out in software.

Non-Ratiometric Configuration - Voltage Reference error. The 5.0VDC voltage reference is accurate to 0.5%. This can be a significant source of error in some applications, but can be easily measured and compensated for.

Changing the Data Rate

You can change the data rate for each Analog Input from 1 millisecond to 1 second. By default, the analog input data set is sent to the PC every 8ms. If, for example, you set the data rate to 1ms, you will receive a packet containing 8 milliseconds worth of 1 ms samples every 8ms. For values less than 8 ms, the data rate sets the sampling rate, not the transmission rate. When the Data rate is set at a multiple of 8 ms, the data rate sets both the sampling rate and the transmission rate.

There is also a limit as to how many channels can be set at a high sampling rate, since you will, at one point run out of bandwidth. We estimate that you can set up to 4 channels to 1ms or you could set all channels to 2ms. You will get an error when you exceed the available bandwidth, warning you of lost data samples.

Setting the data rate at 1, 2, or 4ms will not allow you to react to received sensor data any faster than every 8ms. You will simply get more sample data. This feature is useful if you need to log sensor data at less than 8 ms resolution.

Note that data rate is limited to at most 16ms when opening over the Phidget Webservice. Actual data rate will depend on network latency.

Connecting non-Phidget devices to the Analog Inputs

Here are some circuit diagrams that illustrate how to connect various non Phidgets devices to the analog inputs on your Phidget.

Sensing the value of a variable resistance sensor

In this diagram, an FSR (Force Sensitive Resistor) is shown.

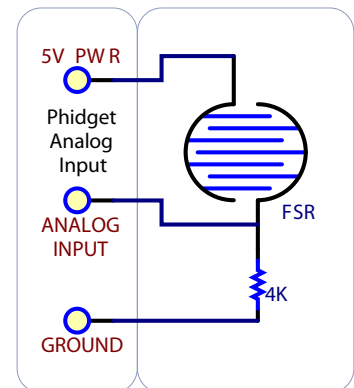

Sensing the position of a potentiometer

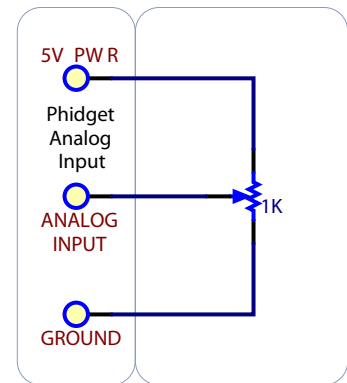

Interfacing to an arbitrary sensor

Note the use of power supply decoupling and the RC Filter on the output. The RC filter also prevents VOUT from oscillating on many sensors

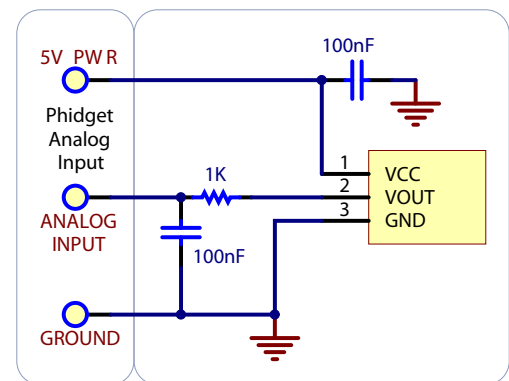

Non Phidgets Sensors

In addition to Phidgets sensors, any sensor that returns a signal between 0 and 5 volts can be easily interfaced. Here is a list of interesting sensors that can be used with the PhidgetInterfaceKit 8/8/8. Note: these sensors are not "plug & play" like the sensors manufactured by Phidgets.

Analog Sensors		
Manufacturer	Part Number	Description
MSI Sensors	FC21/FC22	Load cells - measure up to 100lbs of force
Humirel	HTM2500VB	Humidity sensors
Measurement Specialties	MSP-300	Pressure sensors - ranges up to 10,000 PSI
Freescale Semiconductor	MPXA/MPXH	Gas Pressure Sensors
Allegro	ACS7 series	Current Sensors - ranges up to 200 Amps
Allegro	A1300 series	Linear Hall Effect Sensors - to detect magnetic fields
Analog	TMP35 TMP36 TMP37	Temperature Sensor
Panasonic	AMN series	Motion Sensors
Honeywell	FS01, FS03	Small, accurate Piezo-resistive load cells
AllSensors-Europe	BARO-A-4V	Barometric Pressure Sensor - 600 to 1,100 mbar

Note: Most of the above components can be bought at www.digikey.com

Digital Inputs

Digital Input Hardware Filter

There is built-in filtering on the digital input, to eliminate false triggering from electrical noise. The digital input is first RC filtered by a 15K/100nF node, which will reject noise of higher frequency than 1Khz. This filter generally eliminates the need to shield the digital input from inductive and capacitive coupling likely to occur in wiring harnesses.

Digital Input Hysteresis

The digital input has hysteresis - that is, it will hold it's current state (false or true), unless a large change occurs. To guarantee FALSE, the digital input must be at least 3.75V, and to guarantee TRUE, the digital input must be less than 1.25V.

Digital Input Sampling Characteristics

The state of the digital inputs are reported back to the PC periodically. During this sampling period, if a digital input was true for greater than 4.0ms, the digital input is guaranteed to be reported as true in software. This makes the digital input much more sensitive to reporting TRUE state, and makes it useful to watch for short events. Any Digital Input True events of less than 1.5ms are never reported.

5Volt Terminal Block

For users who need it, we provide 5V on the terminal block next to Digital Input 7.

Functional Block Diagram

The digital inputs have a built in 15K pull-up resistor. By connecting external circuitry, and forcing the input to Ground, the Digital Input in software will read as TRUE. The default state is FALSE - when you have nothing connected, or your circuitry (switch, etc) is not pulling the input to ground.

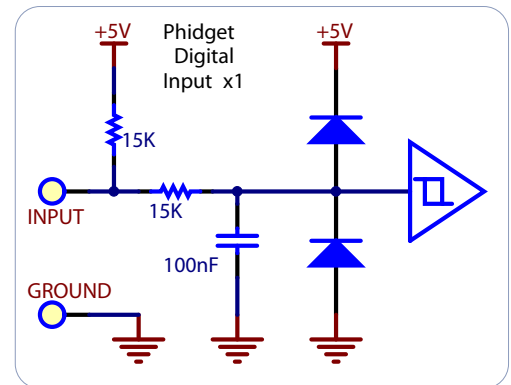

Using the Digital Inputs

Here are some circuit diagrams that illustrate how to connect various devices to the digital inputs on your Phidget.

Wiring a switch to a Digital Input

Closing the switch causes the digital input to report TRUE.

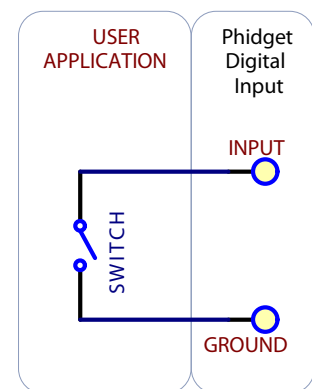

Monitoring the position of a relay

The relay contact can be treated as a switch, and wired up similarly. When the relay contact is closed, the Digital Input will report TRUE.

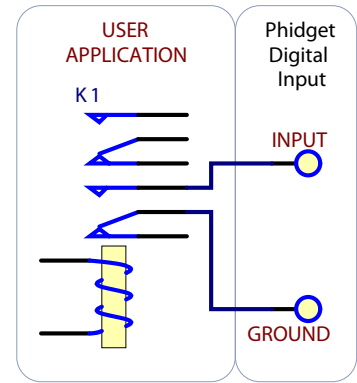

Detecting an external Voltage with an N-Channel MOSFET

A MOSFET can be used to detect the presence of an external voltage. The external voltage will turn on the MOSFET, causing it to short the Digital Input to Ground.

If the MOSFET is conducting $> 270\mu\text{A}$, the Digital Input is guaranteed to report TRUE.

If the MOSFET is conducting $< 67\mu\text{A}$, the Digital Input is guaranteed to report FALSE.

The voltage level required to turn on the MOSFET depends on the make of MOSFET you are using. Typical values are 2V-6V.

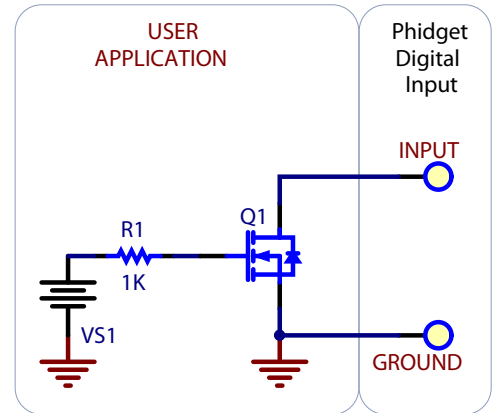

Isolating a Digital Input with an Optocoupler

When driving current through the LED, the Digital Input will report TRUE. The amount of current required will depend on the optocoupler used. Design to sink at least $270\mu\text{A}$ to cause the digital input to report TRUE, and less than $67\mu\text{A}$ to report FALSE.

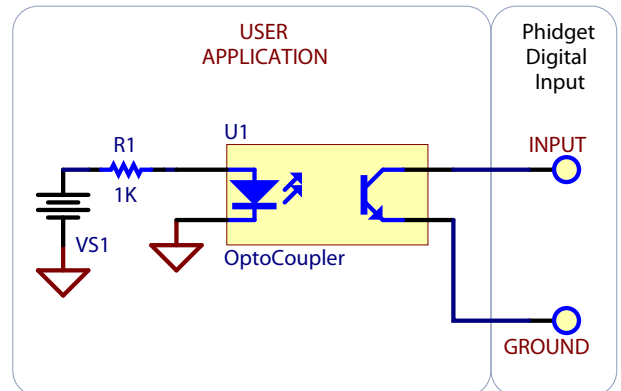

Detecting an external Voltage with an NPN Transistor

This circuit can be used to measure if a battery is connected, or if 12V (for example) is on a wire.

By designing to have Collector-Emitter current $> 270\mu\text{A}$, the digital input will report TRUE.



Using a Capacitive or Inductive Proximity Switch

Capacitive proximity switches can detect the presence of nearby non-metallic objects, whereas inductive proximity switches can detect only the presence of metallic objects. To properly interface one of these proximity switches to the digital inputs, a 3-wire proximity switch is required, as well as an external power supply.

We have checked the following switch from Automation Direct to verify that it works with the Digital Inputs. Similar capacitive or inductive proximity switches from other manufacturers should work just as well.

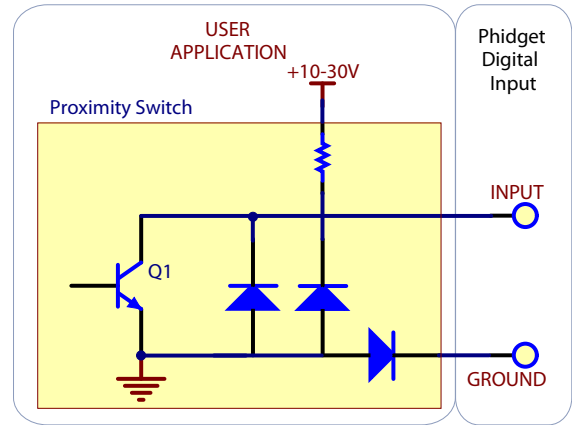

Manufacturer	Web Page	Capacitive Part No	Inductive Part No
Automation Direct	www.automationdirect.com	CT1 Series	AM1 Series

Using an FSR or other variable resistor as a switch

The digital inputs can be easily wired to use many variable resistors as switches.

If the resistance falls below 3.75k Ohms, the Digital Input will go TRUE.

If the resistance rises above 75k Ohms, the Digital Input will go FALSE.

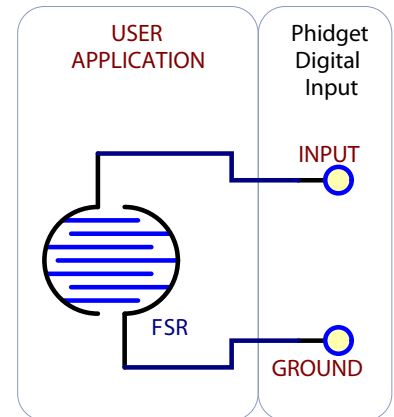

Digital Outputs

Functional Block Diagram

The 250 ohm resistance is internal to the PhidgetInterfaceKit 8/8/8, and limits the current that can flow through the output. This is intended to protect the device from being damaged if there is a short to ground or if an LED is used. The output is intended to drive TTL or CMOS inputs; it is not designed to provide power to an external circuit.

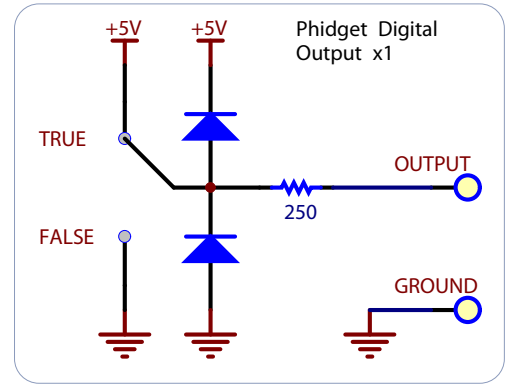

Ground Protection

Ground terminals on the InterfaceKit share a common ground with USB ground. Because they are not internally isolated, these terminals will expose the USB ground potential of the PC to which they are connected. Be sure you are completely familiar with any circuit you intend to connect to the InterfaceKit before it is connected. If a reverse voltage or dangerously high voltage is applied to the input or output terminals, damage to the Phidget or the PC may result.

5Volt Terminal Block

For users who need it, we provide 5V on the terminal block next to Digital Output 7.

Using the Digital Outputs

Here are some circuit diagrams that illustrate how to connect various devices to the digital outputs on your Phidget.

Driving an LED with the Digital Output

Connecting an LED to a digital output is simple. Wire the anode to a digital output labeled 0 to 7 on the Interface Kit, and the cathode to a supplied ground, labeled G.

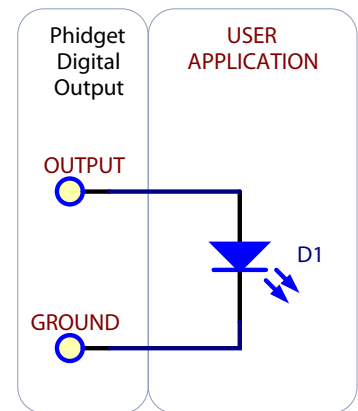

Using a 3052 SSR Board with a Digital Output

Setting the digital output to true causes the output of the 3052 to turn on. This can be used to control AC or DC devices. The load can also be switched with the 3052 on the high side. High side switching is helpful for powering more complicated circuitry that cannot tolerate having multiple grounds.

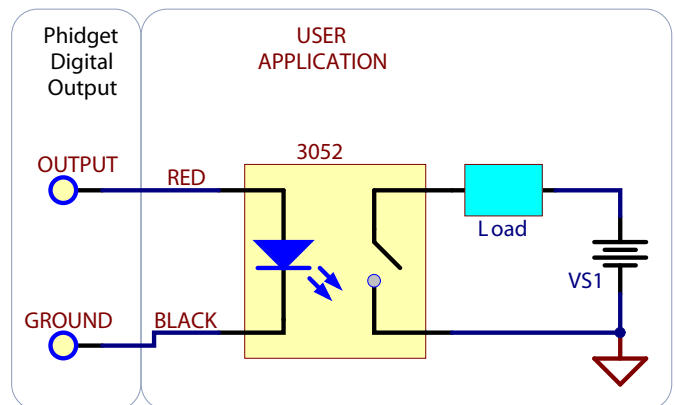

Isolating a Digital Output with a MOSFET based SSR

It's possible to wire up your own Solid State Relay to the digital output. MOSFET based SSRs have the advantage that they can be understood as being a simple switch. There are many other types of SSRs that are more suitable for controlling higher power, higher voltage AC devices that can also be controlled in the same fashion.

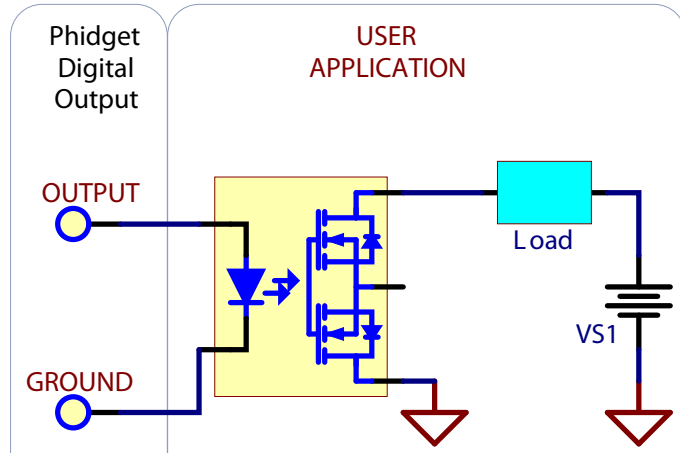

Isolating a Digital Output with an Optocoupler

In some applications, particularly where there is a lot of electrical noise (automotive), or where you want maximum protection of the circuitry (interactive installations, kiosks), electrical isolation buys you a huge margin of protection.

Driving the LED causes the output transistor to sink current. The maximum current through the transistor will depend in part on the characteristics of the optocoupler.

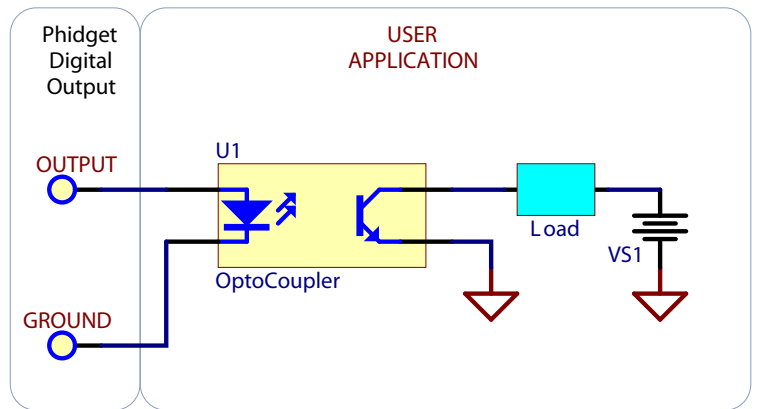

Controlling a relay with a N-Channel MOSFET

A inexpensive mosfet and flyback diode can be used to control larger loads - relays for example - directly from the digital output.

Be sure to use a Logic-Level MOSFET so that the +5V Digital Output is able to turn it on.

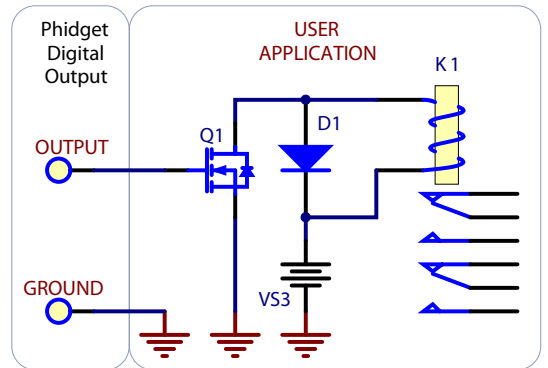

Controlling a relay with a NPN transistor

This circuit is very similar to the N-channel mosfet - but you may already have NPN transistors on hand.

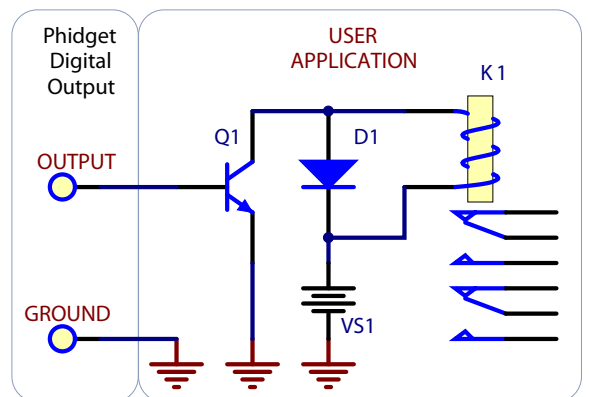

Using a 3051 Dual Relay Board with one or two Digital Outputs

The 3051 Dual Relay Board is designed to be used with the PhidgetInterfaceKit 8/8/8. An Analog Input can be used to supply power to the relays, and one or two digital outputs used to control the relays. The 3051 is a good option if you need a couple relays in your project.

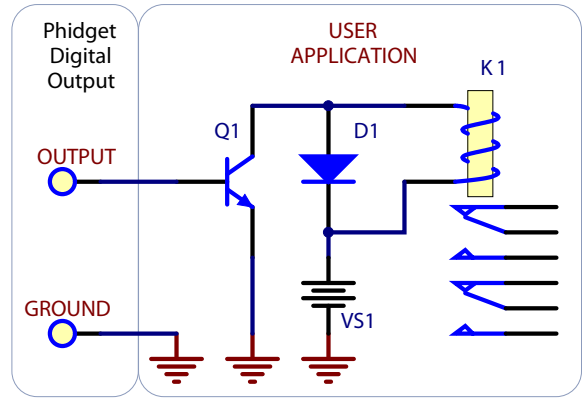

Device Specifications

Characteristic	Value
Board	
USB Voltage	4.75 to 5.25 V
USB-Power Current Specification	Max 500 mA
Quiescent Current Consumption	13 mA
Available External Current (source)	487 mA
Analog Inputs	
Impedance	900K ohms
5V Reference Error	Max 0.5%
Update Rate	1000 samples/second max for 4 channels 500 samples/second max for all 8 channels 62.5 samples/second max over webservice
Digital Inputs	
Pull-Up Resistance	15K ohms
Low Voltage (True)	1.25V Max
High Voltage (False)	3.75V Min
Maximum Voltage	±15V
Update Rate	~125 samples/second
Recommended Wire Size	16 - 26 AWG
Wire Stripping	5-6mm strip
Digital Outputs	
Series Resistance	300 ohms
Update Rate	~125 samples/second
Recommended Wire Size	16 - 26 AWG
Operating Temperature	0 - 70°C

Product History

Date	Board Revision	Device Version	Library Version	Comment
July 2007		824		Product Release
September 2007		825		SPI Overclocking issue fixed
May 2008	1	826		Added RC Filtering to Digital Inputs, PCB X Dimension increased to 3.27"
April 2010	2	900	2.1.6.20100406 or later	Configurable data sampling speed. Replace USB connector with Mini-USB connector

Support

Call the support desk at 1.403.282.7335 9:00 AM to 5:00 PM Mountain Time (US & Canada) - GMT-07:00

or

E-mail us at: support@phidgets.com