

P向局部

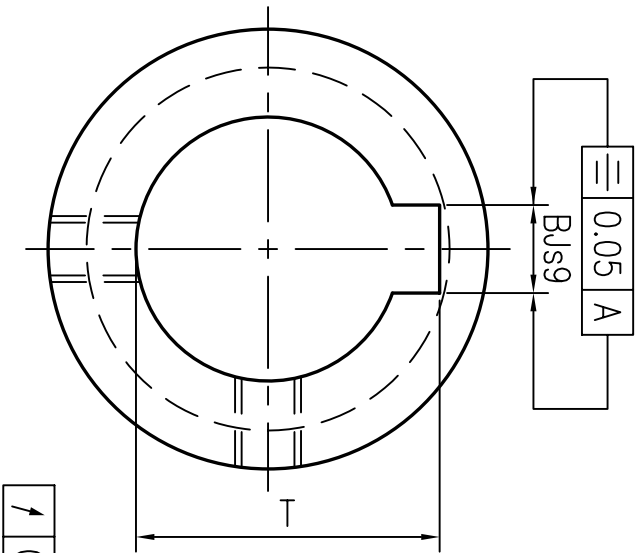

技术要求

- 1.未注倒角C0.5,锐边倒钝去毛刺;
- Unquoted chamfer C0.5 break sharp edges
- 2.各表面不得有划伤,锈迹等缺陷;
- All surfaces must be rust free and no scratch
- 3.未注尺寸公差按ISO 2768-MK标准;
- dimensions without tolerance according to 2768-MK
- 4.齿部淬火处理HRC4.0~4.5,涂防锈油;
- Teeth induction hardened HRC4.0-4.5,coated with antirust oil;
- 5.产品打字,装配紧定螺钉;Marking part No, Setscrews installed

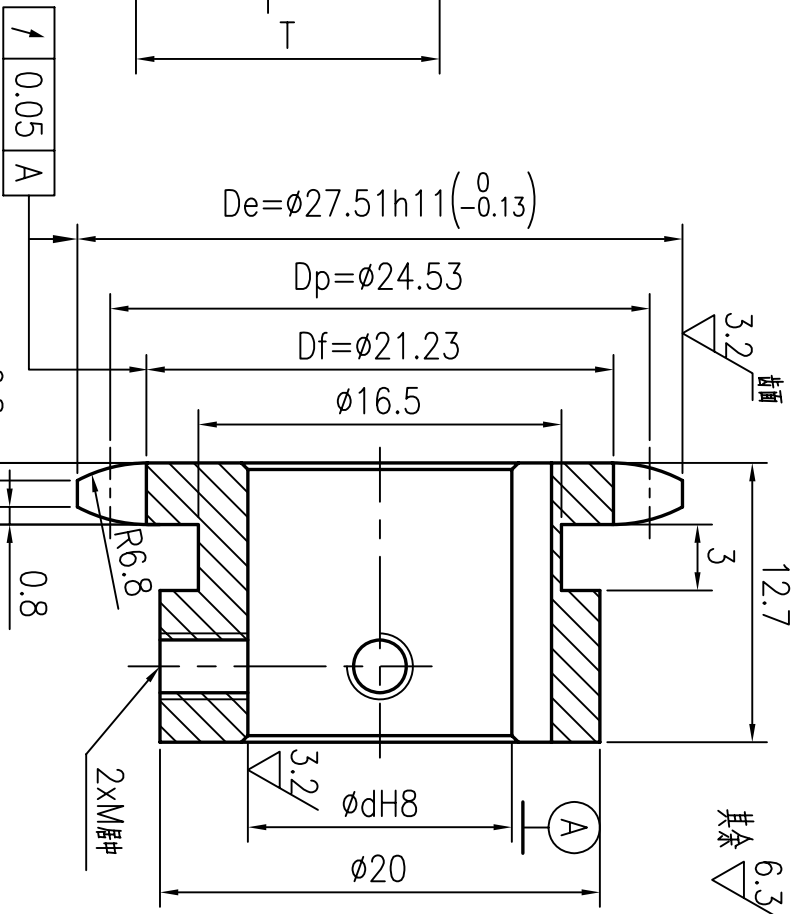

链轮齿数	Z	12
配用链条节距	P	6.35
配用链条滚子外径	d	φ3.3
测量距	Lx	21.23 ⁰ _{-0.13}
标准	ANSI B29.1; 25B	

产品编号/Part No.	d	T	B	M
TRM4139_0	12 ^{+0.027} ₀	13.8 ^{+0.1} ₀	4±0.015	M4
TRM4143_0	12.7 ^{+0.027} ₀	14.29 ^{+0.1} ₀	3.18±0.015	8-32UNC

名称/Name: 链轮		型号/Code: 25B,Z12	
图号/Drawing No: TRM4139_0~4143_0	材料/Material: C45	重量	比例 3:1
更新/Rev	设计 张	更改文件号 Zhang	审核 huang
	日期	标准化	日期
	日期	日期	日期

