

P向局部

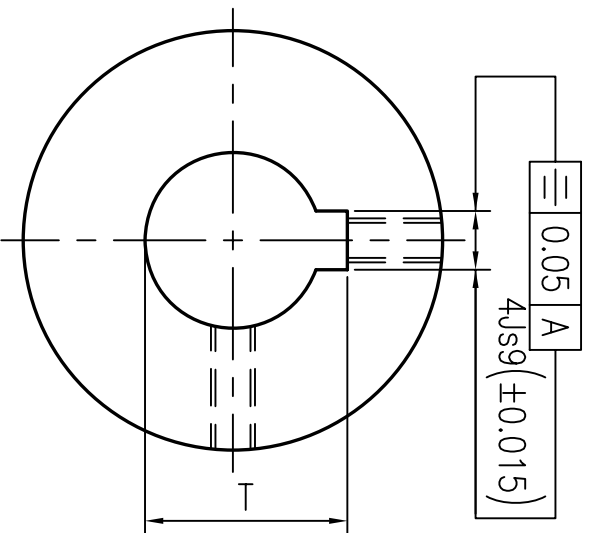

技术要求

- 1.未注倒角0.5,锐边倒钝去毛刺;
Unquoted chamfer (0.5,break sharp edges
- 2.各表面不得有划伤,锈迹等缺陷;
All surfaces must be rust free and no scratch
- 3.未注尺寸公差按ISO 2768-MK标准;
dimensions without tolerance according to 2768-MK
- 4.齿部淬火处理HR(C4.0~4.5,涂防锈油;
Teeth induction hardened HR(C4.0-4.5,coated with antirust oil;
- 5.产品打字,装配紧定螺钉,Marking part No,Set screws installed

0.06 A

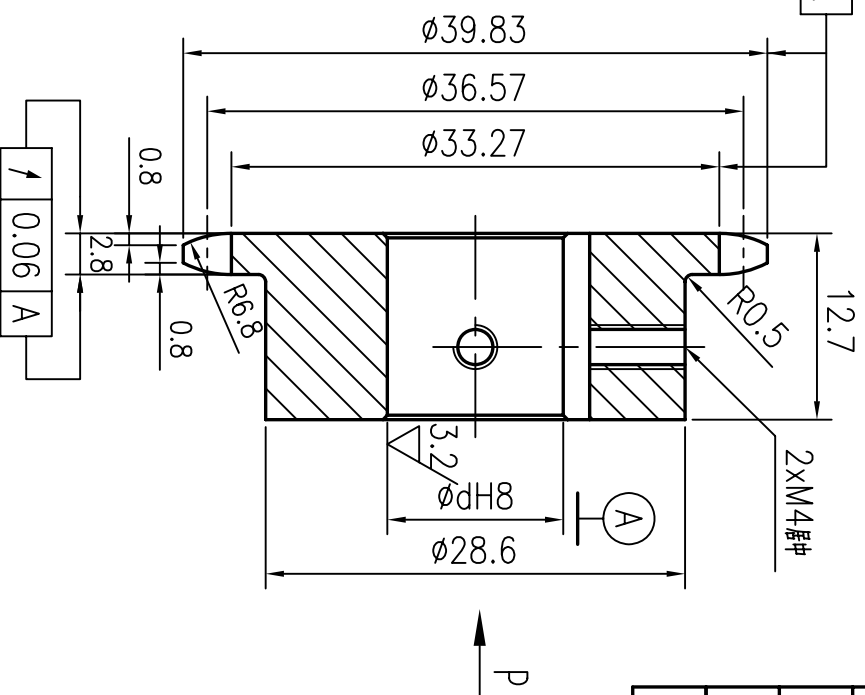

6.3/ 其余

链轮齿数	Z	18
配用链条节距	P	6.35
配用链条滚子外径	d	$\phi 3.3$
测量距	Lx	$33.27_{-0.12}^0$
标准	ANSI B29.1:25B	

标记	外数	更改文件号	签字	日期
设计	zhang	标准化		
审核	huang			
工艺		日期		

名称/Name:	链轮
型号/Code:	25B,Z18
共	页
第	页

产品编号/Part No.	d	T
TRM4136_0	$9_{0}^{+0.027}$	$10.8_{0}^{+0.1}$
TRM4140_0	$12_{0}^{+0.027}$	$13.8_{0}^{+0.1}$

图号/Drawing No:	TRM4136_0~4140_0	更新/Rev
材料/Material:	C45	重量
		比例
		2:1
 Chengdu Leno Machinery Co.,Ltd Tel:+86-28-65998825; Fax:+86-28-84862968 sales@cdleno.com; www.cdleno.com		