

# 产品选型手册

Product selection guide

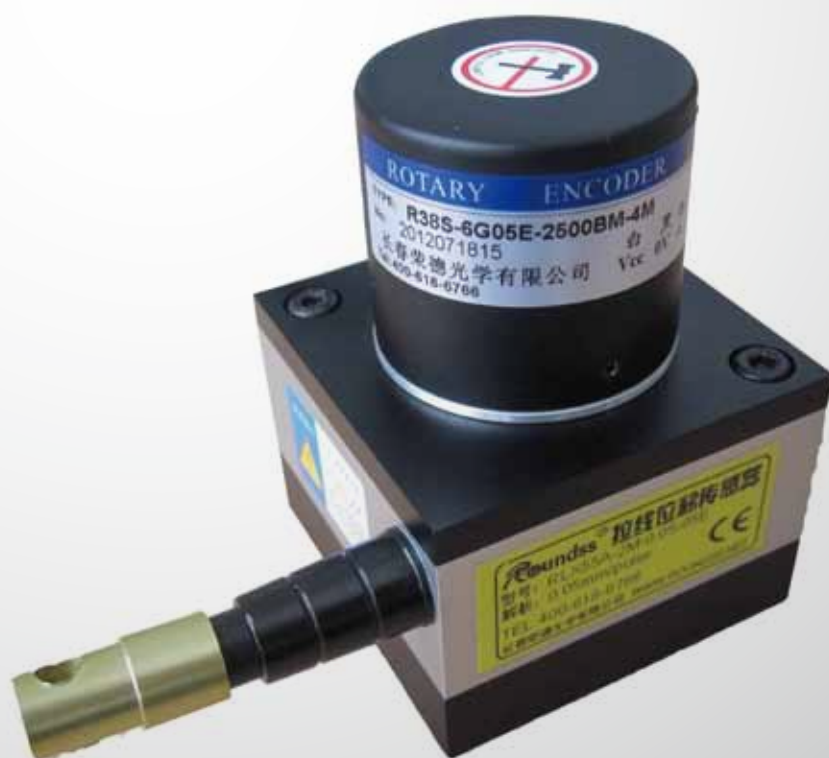

RLC50D Draw Wire Sensor

# Digital Signal Output Type



Incremental encoder and absolute encoder are optional for the digital signal output type. Output signals are square wave ABZ signals or Gray code signals. Measurement range is up to 1500mm. Linear accuracy: 0.05% FS. Resolution based on the different configuration can reach 0.001mm / pulse in maximum. Working temperature: -30 ° C-+90 ° C.

## Part Number

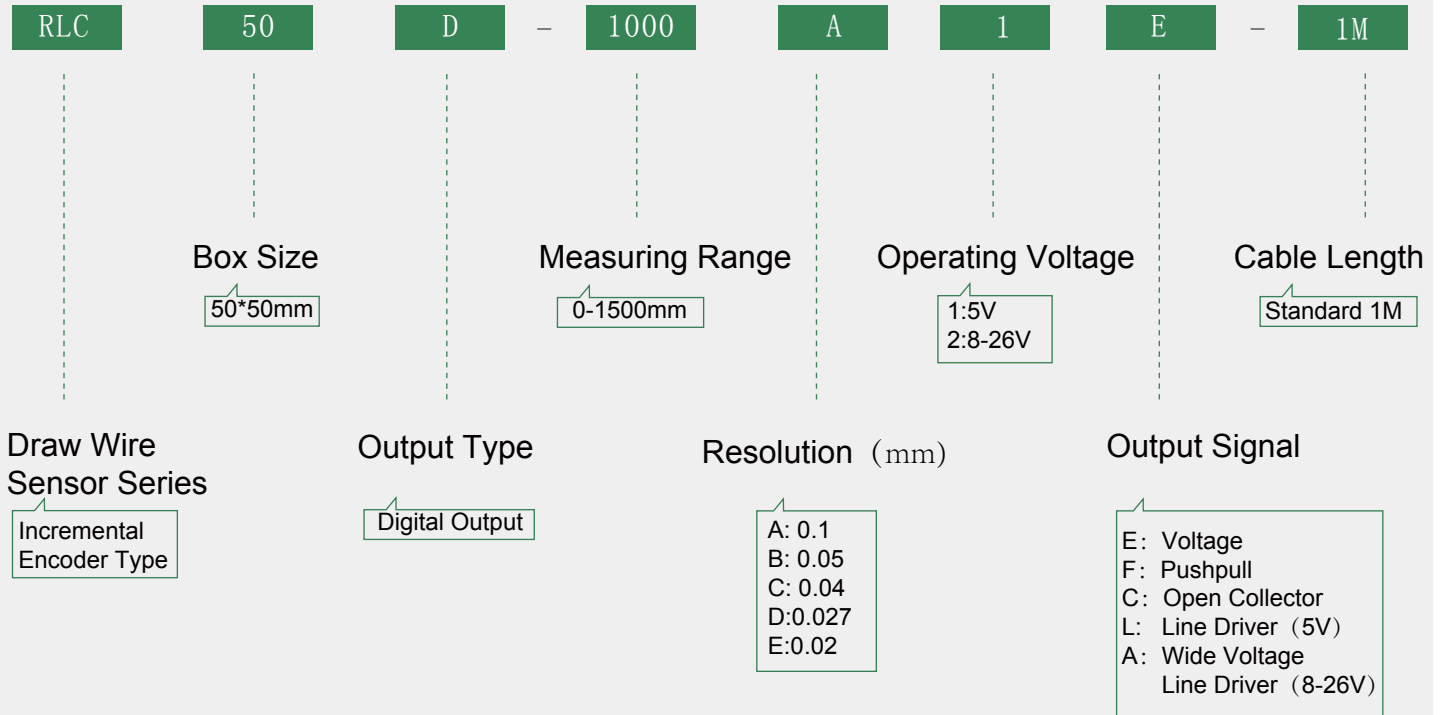

## Mechanical Specifications

Measuring Range	0—1500mm optional
Housing	Aluminium alloy, oxidation surface treating, wear and corrosion prevention
Wire Rope	0.6mm high flexible imported plastic coated wire rope
Wire retraction force (min)	appr. 1N
Wire extension force (max)	appr. 2.5N
Linear Accuracy	0.05%FS
Repeatability Accuracy	0.01%
Life	>10 million times

# Electrical Specifications

Sensor Element	Incremental Encoder				
Electrical Connection	Cable Radial, 1m				
Output Model	Voltage	Push-Pull	Open Collector	Line Driver (5V)	Wide Voltage Line Driver (8-26V)
Operating Voltage	DC5V/8-26V				
Sensor Resolution(mm)	0.1	0.05	0.04	0.027	0.02
Encoder Resolution (ppr)	1000	2000	2500	3600	5000
Max. Reciprocating Speed	1000mm/s				
Reciprocating Frequency	50 Hz(See Reciprocating Amplitude)				

# Environmental Specifications

Temperature Range	-30°C—90°C
Vibration Resistance	10HZ—1500HZ 10G
Protection Class	IP54(Standard)
Weight(kg)	0.485

# Output Circuit

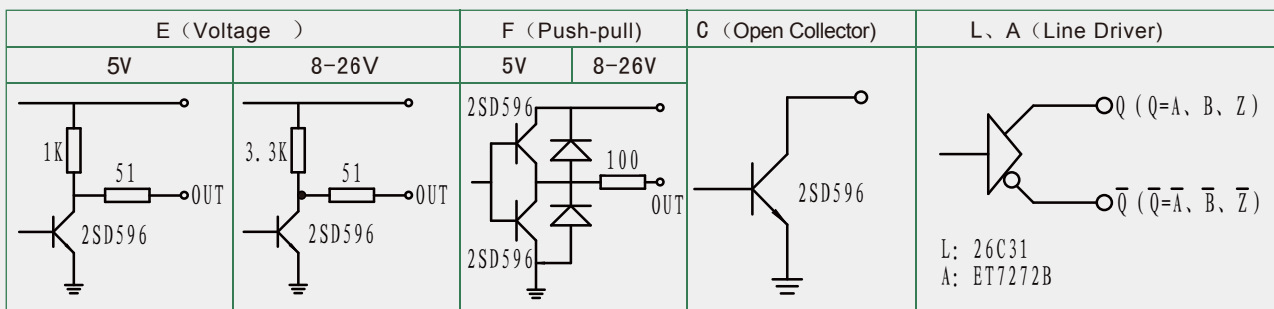

Note: C, F output provide ground protection diode

# Output Waveform

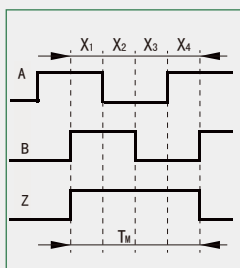

Waveform for C, E, F output

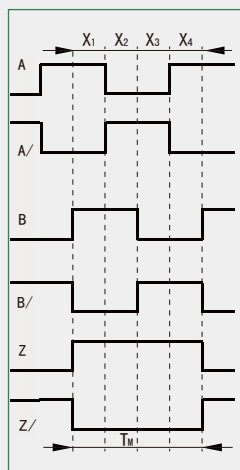

Waveform for L, A output

- Wave Ratio :  $X_1+X_2=0.5T \pm 0.1T$   
 $X_2+X_3=0.5T \pm 0.1T$
- Phase Different :  $X_n \geq 0.125T$  ( $n=1, 2, 3, 4$ )
- Absolute Angle Error:  $\leq 0.2T$
- Cycle Error :  $\leq 0.05T$
- $T=360^\circ / N$  ( $N$ =lines count per revolution)
- Width of Z signal
- $T_m=1T \pm 0.5T$   
 $T_m=nT \pm 0.1T$  ( $n \geq 2$ )
  - The phase relationship of Z signal and A, B signal is not stipulated.
- 2、 $T_m=0.5T \pm 0.25T$   
 $T_m=0.25T \pm 0.125T$   
 $T_m=0.25T \pm 0.125T$

The picture shows the clockwise (CW) waveform from the shaft side.

Cable Color	Red	Yellow	White	Black	Green	Grey	Brown	Orange	Shield
Line Driver	Vcc	Z	B	OV	A	B/	A/	Z/	G
Voltage	Vcc	Z	B	OV	A	-	-	-	G
Open Colletor	Vcc	Z	B	OV	A	-	-	-	G
Push-pull	Vcc	Z	B	OV	A	-	-	-	G

## Mechanical Drawings

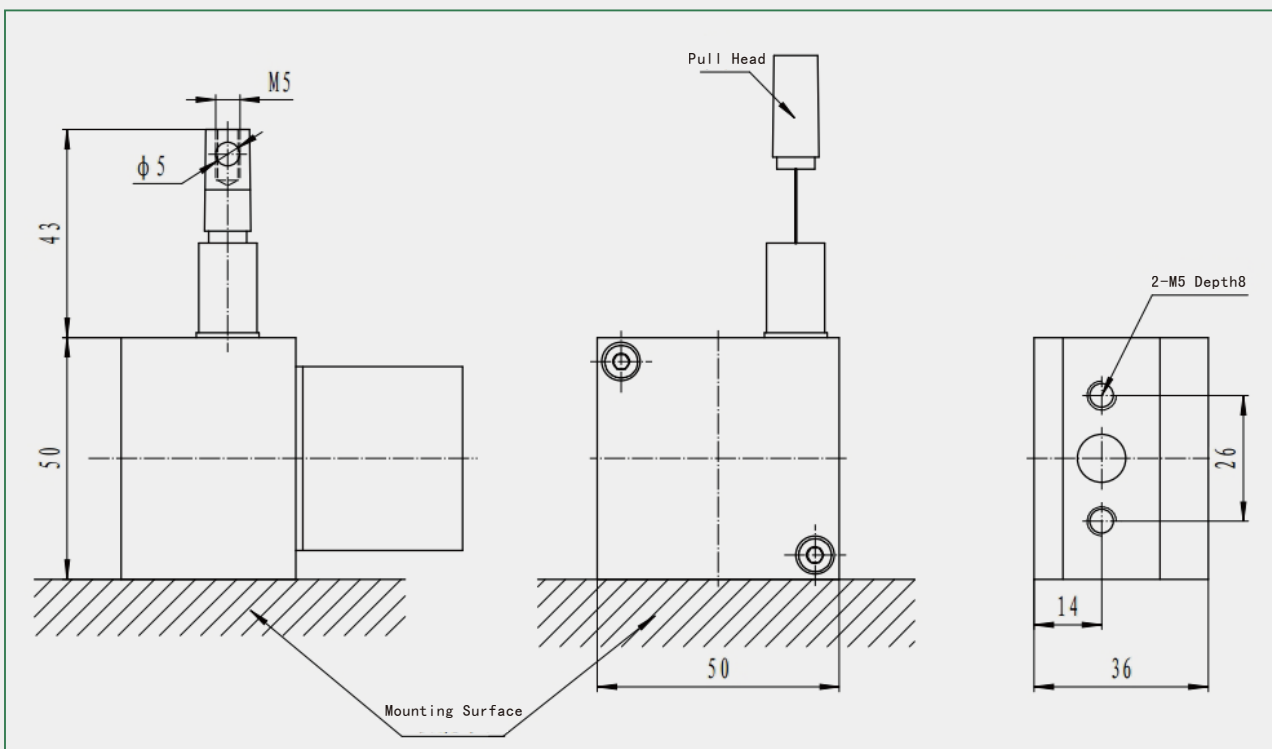

## Notes

1. Damage may occur if wire is released and allowed to retract without tension.
2. Make certain the wire path is clear of objects or sharp edges to prevent wire damage.
3. Wire should exit as straight as possible. A pulley may be used to redirect it.
4. Please connect the cable according to the specifications of electrical connections.  
Make sure the connections are correct when power is on.
5. Draw wire sensor is a precision instrument. Knocking is forbidden.  
Please ensure the cleanness of the equipment and wire to prolong the service life.
6. Avoid external force on wire.
7. Do not self-dismantle for that the strong spring inside the sensor may hurt you.

