

36PA5. 2G/42BYG40-160-4A

Measurements are in mm

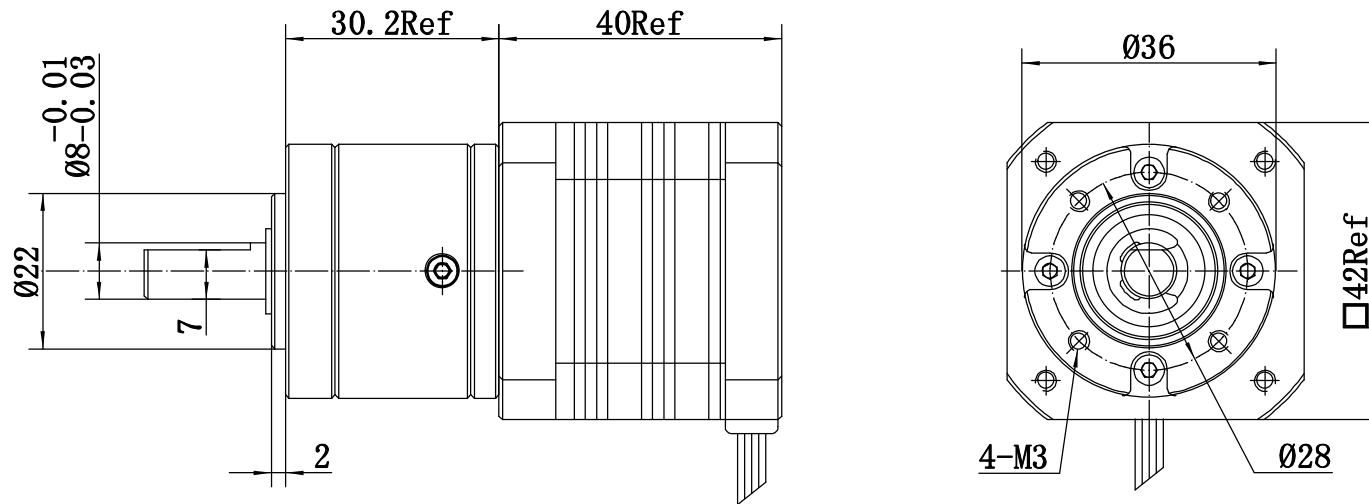

Gear motor parameters

| | | | | | | | | | |
|------------------|------|---------------|------------|-----|---------------------------|-----------------------|--|--------------|--|
| Step angle | 步距角 | 1.8° | | | GEAR PLANET STEPPER MOTOR | | 上海致贝电子有限公司 Shanghai zhibei electron Co., Ltd. | | |
| Motor Length | 机身长度 | 40mm | | | | | | | |
| Phase voltage | 相电压 | 2.78V | | | 36PA5. 2G/42BYG40-160-4A | | www.sh-jingkong.com TEL:86-21-64893314; FAX: 86-21-64894075 | | |
| Phase current | 相电流 | 1.6A | | | | | | | |
| Phase Resistance | 相电阻 | 1.73 Ω | Design | 盛培明 | 2011.02.25 | material | | Edition | |
| Phase Inductance | 相电感 | 3.2mH | Drawing | 盛培明 | 2011.02.25 | | | | |
| Holding Torque | 静力矩 | 3600g. cm | Inspection | | | superficial treatment | | SCALE 1:1 A4 | |
| Lead Wire | 引线数 | 4 | Approver | | | | | | |
| Reduction ratio | 减速比 | 5.2 | | | | | | | |

A

B

C

D

E

F